



SLD1964 V1

19" TFT LCD Display, LED Backlight, 800nits, SXGA(1280x1024)

19" TFT LCD panel, built-in 800 nits high brightness, high transmittance color filter, high transmission polarizing plates, Low Power Consumption, suitable for kiosk, advertising, POS, marine, transportation, gaming, studio display, gas pump.

Key Features

- 800nits
- LED Backlight
- SXGA(1280x1024) High Definition
- High Shock & Vibration Resistance
- Smart Panel design. The thickness is only 36.5mm
- High Uniformity
- Low EMI Noise
- Wide Dimming
- Life Expectancy



Specifications

Ver2

Model No.	SLD1964 V1
Description	19" TFT LCD Display, LED Backlight, 800nits, SXGA(1280x1024)
Display Area (mm)	376.3 x 301.1mm
Brightness	800 cd/m ²
Resolution	1280x1024 (SXGA)
Contrast Ratio	1000 : 1
Pixel Pitch (mm)	0.294(H) x 0.294(V)
Viewing Angle	+85°~ -85°(H), +80°~ -80°(V)
Display Colors	16.7M
Response Time (Typical)	5ms
Power Consumption	20W
Dimensions (mm)	396x326x35.9mm
Weight (Net)	2.75kg
LED Driving Board	LID19A10
Control Board (Optional)	<input type="checkbox"/> AD6038GA <input type="checkbox"/> AD6038GD <input type="checkbox"/> AD2662GDVAR <input type="checkbox"/> AD2662GDHMVAR
<input type="checkbox"/> AD6038GA	VGA+Audio
<input type="checkbox"/> AD6038GD	VGA+DVI
<input type="checkbox"/> AD2662GDVAR	VGA+DVI (Optional S-Video/ Component / Audio)
<input type="checkbox"/> AD2662GDHMVAR	VGA (Optional DVI-D / HDMI / S-Video/ Component / Audio)
F / R Control Button	<input type="checkbox"/> 5 Key <input type="checkbox"/> 4 Key
<input type="checkbox"/> 5 Key	Power Switch, Menu, Select (+,-), Auto
<input type="checkbox"/> 4 Key	Power Switch, Menu, Select (+,-),
OSD Menu	Brightness, Contrast, H/V Position, Color, Phase, Clock...
Optional	<input type="checkbox"/> AOT <input type="checkbox"/> Touch Screen

Specifications are subject to change without notice.

All brands or product names are trademarks or registered trademarks of their respective companies.



Mechanical Drawing

Outline Dimensions

Unit: mm

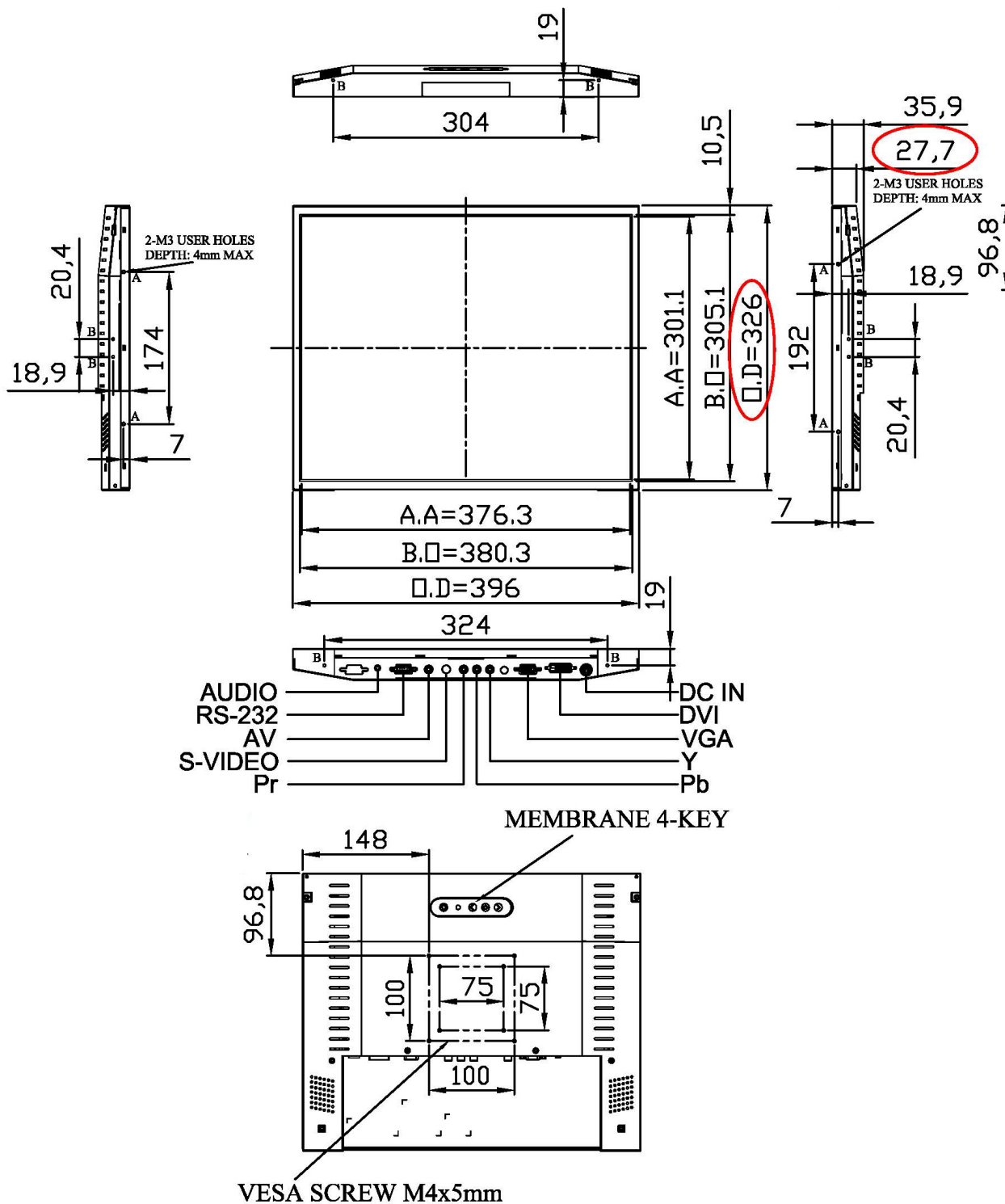

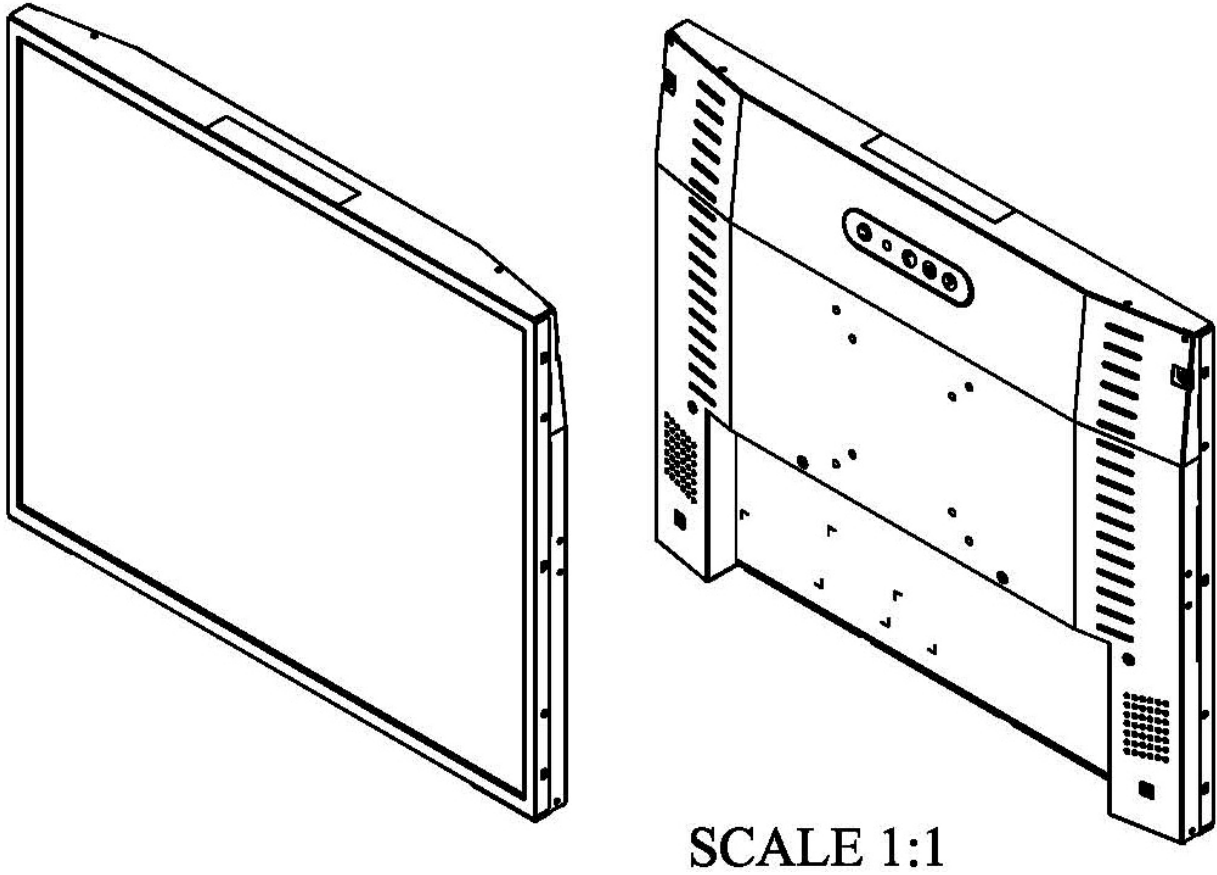

Ordering Information

Part Number	Description
SLD1964-ENB-G11	19",800nits,SXGA,LID19A10,AD2662GD,O/B,V02(2 in 1)

Optional Accessories

Part Number	Description
840612051210	ADAPTER,AC/DC,12V/5.4A,65W,Atech OEM A065112-TDx.4P,P
810618301010	CABLE.POWER.AC.1830mm USA type
810618301090	CABLE,POWER,AC,1830mm Europe type
810618301050	CABLE.POWER.AC.1830mm UK type
810618301170	CABLE.POWER,AC,1830mm Australia type
810618301030	CABLE.POWER.AC.1830mm Japan type