



www.ipc-markt.de

# Industrial Monitor HB-15

## Sunreadable Outdoor TFT



### Features

- Coated Protective Security Glas
- Excellent Brightness & Contrast
- Autodimming
- Full Metall sheet Chassis
- VESA - Holder

### Optional Accessories

| Model NO.                  | HB-15         |                                 |
|----------------------------|---------------|---------------------------------|
| Viewing Area               | 15"           |                                 |
| Touch Panel                |               | Option                          |
| Resolution                 | 1024 x 768    | XGA                             |
| Eff. Display Area          | 304,1 x 228,1 | mm                              |
| Colors                     | 256K          |                                 |
| Response Time              | < 12 ms (typ) |                                 |
| Contrast Ratio             | 600 : 1       |                                 |
| Brightness                 | 1000 cd/qm    |                                 |
| Viewing Angle              | H 150 x V 110 |                                 |
| Input Signal               | Analog VGA /  | DVI                             |
| Input Connector            | D-sub 15pin / | DVI                             |
| Scan Frequency             | H: 30- 60 KHz | V: 50-75Hz                      |
| Power Mgmt                 | VESA DPMS     | Standard                        |
| Consumption / Power Supply | 35W @12/24VDC | 12 VDC Adapter<br>24 VDC (opt.) |
| Dimensions (mm)            | See Drawing   |                                 |
| Oper. Temperature          | -10... +60    | Degree C                        |
| Weight                     | 5,8 KG        |                                 |
| Standard                   | IP-65 (Front) | (Optional)                      |



Holder for Mini-IPC  
Back-Site Mounting

Swing Arm

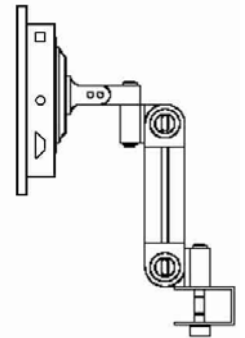

15,1" Panel-Mounting

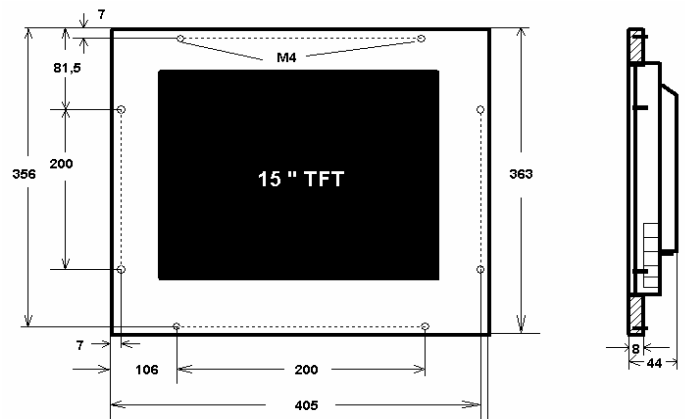

15,1" Rackmounting (19")

